

# C**MAX**

## “CE” CERTIFIED HIGH PERFORMANCE MICROSTEPPING SYSTEMS

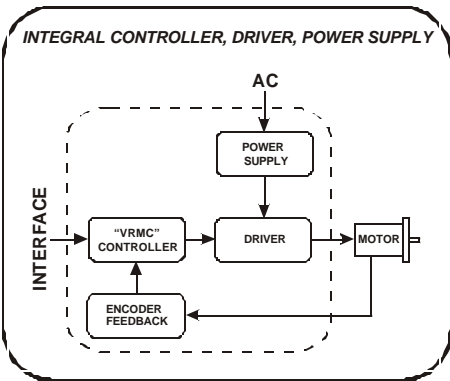

### OVERVIEW

The CMAX systems are high performance microstepping positioning control devices with integrated driver and power supply. Models include the CMAX-410, for general-purpose automation requirements and the CMAX-810 for high torque, high speed applications. Both models are CE certified to meet EMC and Low-voltage / Safety Directives.

The CMAX systems communicate through high speed RS-422 serial protocol. A simple, single character mnemonic command set is used for programming. Operation is in either fixed or variable resolution mode with step resolution to 51,200 steps/rev. Discrete I.O. lines include four user definable and eight dedicated inputs, five general purpose and one dedicated output.

The CMAX systems simplify motion control with standard features such as programmable motor run and hold current, independent acceleration and deceleration ramping and 2k bytes of non-volatile memory for program storage. Short circuit, over temperature and under voltage protection, combined with special "Watchdog" software, provide trouble-free operation in all environments. Encoder feedback is available for closed-loop control.

### FEATURES

- *Integral indexer/driver/power supply*
- *CE certified for international use*
- *Output currents of 4A/40Vdc to 8A/64Vdc (non-CE-8A @ 80 or 160Vdc optional)*
- *1/256 (fixed or variable) motor step resolution*
- *Programmable run/hold current*
- *RS-422 "Party Line" operation*
- *Programmable accel/decel ramps*
- *2K bytes of non-volatile memory*
- *Home/limit inputs*
- *Dual speed jog inputs*
- *Go and soft stop inputs*
- *Four buffered/filtered user input ports*
- *Five general purpose outputs*
- *Programmable trip point*
- *Encoder feedback option*
- *Short circuit, over temperature and under voltage protected*
- *"Watchdog" software for guaranteed reliability*

### THE CE MARK

Today, all industrial electronic apparatus entering the European Union (EU) must be tested to the standards defined by the EMC and Low Voltage / Safety Directives. At the end-user level, displaying a CE (Certificate European) Mark on the equipment indicates compliance with these Directives.

Both CMAX models have undergone extensive development and test to comply with EU Directives 89/336/EEC for Electromagnetic Compatibility and IEC Directive 61010-1 (edition2)-Conformity Testing to Standards for Safety of Electrical Equipment. In addition to the marketing advantages associated with this process, CE approved designs ensure maximum power surge protection, noise immunity and safety features for dependable operation in all environments.



2 Townsend West  
 Nashua, NH 03063  
 www.ams2000.com  
 (603) 882-1447

### CMAX-410

Both CMAX models are designed for use with 2 phase, bi-polar, permanent magnet stepper motors. The CMAX-410 will operate NEMA 23 and single stack 34 frame size motors. Packaged in a compact (4 x 5 x 8 inch long), fan-cooled aluminum enclosure it includes a programmable controller, a 4 amp per phase microstepping driver and a 40Vdc (90VA) power supply. Typical applications include plotting, medical instrumentation, coil winding, labeling, scanning and metering.

### CMAX-810

The CMAX-810 integrates a programmable controller with a powerful 8 amp/phase microstepping driver and a 64Vdc (180VA) power supply for use with the larger 34 and 42 frame size motors. A (non-CE rated) 80Vdc or 160Vdc option is available for higher speed requirements. The enclosure measures 4 x 5 x 11 inches long. Typical applications include cutting, welding, drilling, grinding, and packaging.

### PROGRAMMABLE CURRENT

A programmable current feature controls motor winding current to within 1% resolution. Independent settings for "RUN" and "HOLD" currents permit full motor torque when stepping. Automatic power down to the hold current value minimizes motor power dissipation when the system is in an idle mode of operation.

### INDEPENDENT ACCEL/DECEL RAMP

The CMAX systems feature independent acceleration and deceleration ramping for added flexibility in generating custom motion profiles.

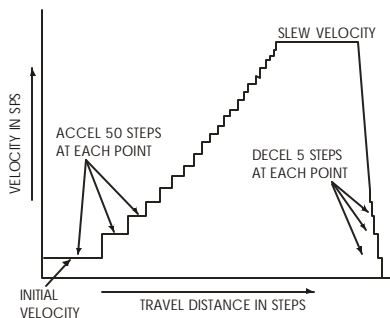

The separate decelerate parameter is a valuable time saver when compared to systems with fixed acceleration and deceleration times.

### PROGRAMMING IN "NV" MEMORY

The CMAX hosts 2,048 bytes of non-volatile memory for storage of operational parameters, speeds and user programs. Direct read and write commands allow host use of the memory. Additionally, 64 bytes of internal RAM is available for "Scratch Pad" (fast read/write) applications.

For stand-alone use there is a "GO" switch input. Additional input ports can test and branch to multiple motion subroutines. Two high power outputs are available to drive solid-state relays and other devices. A separate "TRIP" function provides automatic program branching when a specified motion is passed. Additional control inputs include soft stop, dual speed jog and step-by-step monitoring of travel limits.

### VARIABLE RESOLUTION MICROSTEP CONTROL (VRMC®)

VRMC® is an advanced technology developed by AMS that produces high resolution microstep positioning at slow shaft speeds for silent, resonance free operation. As shaft speed increases, the output step resolution is automatically expanded using a technique known as "on-motor-pole" synchronization. At the completion of a coarse index, the target micro position is trimmed to 1/100 of a step to achieve and maintain precise positioning.

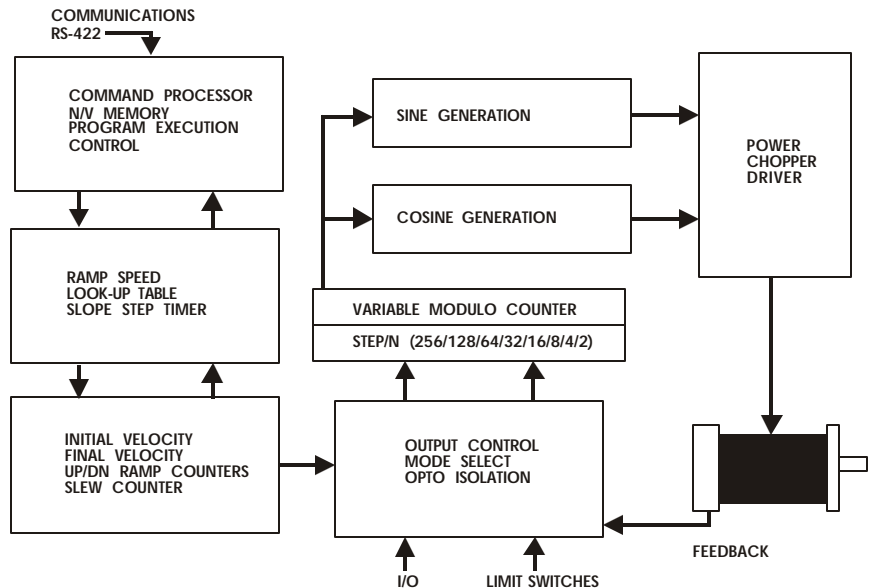

The results are an advanced microstepping controller designed to produce accurate, repeatable positioning with minimal effort and cost.

### SERIAL INTERFACE

Communication is via RS-422 protocol and may operate in either Single or Party Line mode. The Single mode provides user-friendly one axis communication for set-up and debug functions. Party Line permits multiple CMAX units to be controlled from a single communications port.

In Party Line mode differential line drivers and receivers are used to provide reliable communication in noisy environments. This design allows a single Master (or Host) computer and up to 32 Slave controllers to be connected in parallel and permits full duplex communication with all controllers "listening" simultaneously for incoming commands.

## COMMANDS

ESC	Abort/Terminate
@	Soft Stop
^C	Reset
A	Port Read/Write
B	Set Jog Speeds
C	Clear and Restore
c	Reset Driver
D	Divide Step Rates
E	Enable Auto Power Down
F	Find Home (SPS)           G
Go	
H	Step Resolution
I	Initial Velocity (SPS)
J	Jump to Address N + 1(X)K
Ramp Slope	
k	Special Trip
L	Loop on Port
l	Limit Polarity
M	Move at Constant Speed
O	Set Origin
P	Program Mode
Q	Query (List) Program
R	Index to Target Position
S	Store Parameters
T	Trip Point Set
V	Slew Velocity (SPS)
W	Wait N Milliseconds
w	Driver Status
X	Examine Parameters
Y	Hold/Run Currents
Z	Display Position
+	Index in + Direction
-	Index in - Direction
[	Read NV Memory
\	Write to NV Memory
]	Read Limits/Hardware
^	Read Moving Status
	Selective Termination
Encoder Commands:	
A	Stall Count
d	Dead-band Enable
e	Encoder Resolution
f	Find Encoder Mark
h	Hunt Resolution
n	Force Encoder Position
o	Set Origin to Zero
q	Query (List) Programs
r	Set Stall Retry Count
s	Stall Factor
t	Stall Test Data
v	Hunt Velocity
z	Read Encoder Position

## ENCODER FEEDBACK

The CMAX systems support encoder feedback for use in closed-loop, positioning applications. The following elements are used to provide this function:

- Input buffers (two differential input comparators with RC filters) to eliminate noise.
- Digital filters to further sample and shape waveforms.
- A quadrature decoder to convert inputs to count/direction and multiply count by four.
- A 24 bit up/down counter and latch to track encoder position.
- A slave processor that detects and notifies the host CPU of stall or position drift conditions.

## AUXILIARY I.O.

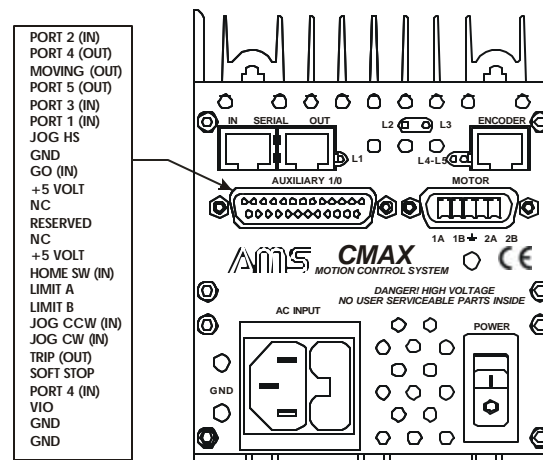

All inputs have RC noise filters, followed by voltage comparators with hysteresis, for high noise immunity. The input threshold voltage is set to 50% of VIO, the input circuit supply voltage. VIO is supplied from the 6 volt bias supply via an isolation diode. An external supply may be used if a higher input voltage

The 25 Pin DB style I.O. connector supports 4 general purpose inputs, 5 general purpose outputs, 8 dedicated inputs, 1 dedicated output, and flexible user support facilities.

## WATCHDOG FUNCTIONS

The CMAX incorporates a special timer that continuously monitors the operation of the microprocessor. If the microprocessor does not respond for some reason, the timer will set a flag that causes an unconditional reset of the system.

A "Power Fail Interrupt" feature detects when a logic power supply voltage is out of tolerance. During power down, or a power interruption, the processor will be held at a reset condition until the proper voltage (5V) is restored.

## FAULT PROTECTION

The CMAX is internally protected against phase to phase and phase to ground short circuits, over temperature and under voltage. Two LEDs on the front panel indicate operating conditions and status.

Each unit is packaged in a specially designed heat-sink with cooling fan to help avoid over temperature conditions. Should an over temperature condition occur however (between 60° C and 70° C), the driver will automatically shut down.

If the DC voltage to the driver drops below the minimum specification, the drivers output stage will be disabled. For added safety, the driver must be reset to enable the outputs when the proper voltage and/or temperature condition is restored.

The short circuit protection consists of phase to phase, phase to ground, and +V to phase. If a phase short to ground fault is detected, the outputs will be disabled and can not be re-enabled without resetting or powering down the driver.

**EASI DISKETTE**

AMS provides free application development software; featuring:

- Program Editor
- Syntax Checker Loader
- Microsoft "C" Source Code
- Pull-Down Menus
- Dumb Terminal Emulation
- Quick Basic Information Program
- Speed, Distance, Accel/Decel Plots

**ENVIRONMENTAL SPECIFICATIONS**

Storage: -45 to 85 Degrees C  
 Operating: 0 to 55 Degrees C  
 Humidity: 0 to 95% (Non-condensing)

**MECHANICAL SPECIFICATIONS**

Weight

CMAX-410: 5.2lbs (2.4kg)

CMAX-810: 9.4lbs (4.3kg.)

Size in inches (mm)

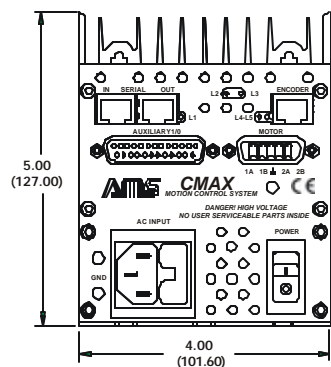

**ELECTRICAL SPECIFICATIONS**

	<u>CMAX-410</u>	<u>CMAX-810</u>
Power Supply.....	40Vdc (90VA)	64Vdc* (180VA)
Output Current (Peak).....	4 Amps	8 Amps
Chopping Frequency.....	28kHz	
Input Voltage.....	100 to 125 VAC; 60Hz or 200 to 250 VAC; 50Hz	
Microsteps (Full Step).....	Variable, 2, 4, 8, 16, 32, 64, 128, 256	
Encoder Resolution.....	50 to 12,750 Lines (in multiples of 50)	
Non-Volatile Memory.....	2k Bytes	
Position Counter.....	±8,388,607	
Baud Rate.....	9600 (Std.), 460k (Selectable)	

\*80 or 160Vdc option available (non- CE rated). Specify at time of order.

I.O. Signals (J3)	Min	Typ	Max	Units
I.O. Supply (VIO)	5	5.4	28	Vdc
Inputs (Ports 1,2,3,4):				
Input Voltage	-0.7	VIO/2	VIO	Vdc
Input Current			500	µA @5V
Outputs (Ports 4,5,6):				
Output Voltage			100	Vdc
Output Current			0.5	Amp (cont)

Control Signals	Min	Typ	Max	Units
Encoder Supply Voltage		5		Vdc
Encoder Supply Current			50	mA
Encoder Inputs	-0.7		5.7	Vdc
Encoder Input Currents		5	10	mA
RS485 Inputs	-10		+15	Vdc
RS485 Outputs		5		Vdc

