

Overview

The BM23 series high torque stepper motors have a 1.8° step angle, NEMA23 dimensions and are available in single or dual shaft versions. They feature 4 leads but can be provided also with 6 or 8 leads upon request. Custom lead length adaptation is available.

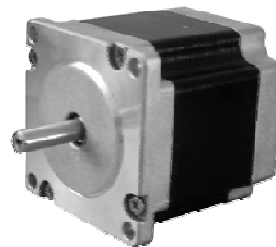

The dual shaft motors are optionally available with a differential encoder (see the last page of this data sheet for more information)

Specifications

Model Number		Current / Phase	Resistance / Phase	Inductance / Phase	Holding Torque	Rotor Inertia	Weight	Detent Torque	Length
Single Shaft	Dual Shaft	A	Ω	mH	kg-cm (oz-in)	g-cm ²	kg	kg-cm	mm
BM23-76-S	BM23-76-D	2.8	0.7	1.4	5.5 (76)	120	0.45	0.21	41
BM23-140-S	BM23-140-D	2.8	0.83	2.2	10.1 (140)	275	0.65	0.36	51
BM23-175-S	BM23-175-D	2.8	0.9	2.5	12.6 (175)	300	0.7	0.4	56
BM23-262-S	BM23-262-D	2.8	1.13	3.6	18.9 (262)	480	1	0.68	76

Step Angle	1.8°
Step Angle Accuracy	±5% (full step, no load)
Resistance Accuracy	±10%
Inductance Accuracy	±20%
Temperature Rise	80°C max. (rated current, both phases on)
Ambient Temperature	-20°C ~ +50°C
Insulation Resistance	100MΩ min., 500VDC
Dielectric Strength	500VAC for one minute
Shaft Radial Play	0.02 max. (450 g load)
Shaft Axial Play	0.08 max. (450g load)
Max. Radial Force	78N (20mm from the flange)
Max. Axial Force	15N
Direction of Rotation	CW (when viewing from the front flange)

Dimensions in mm

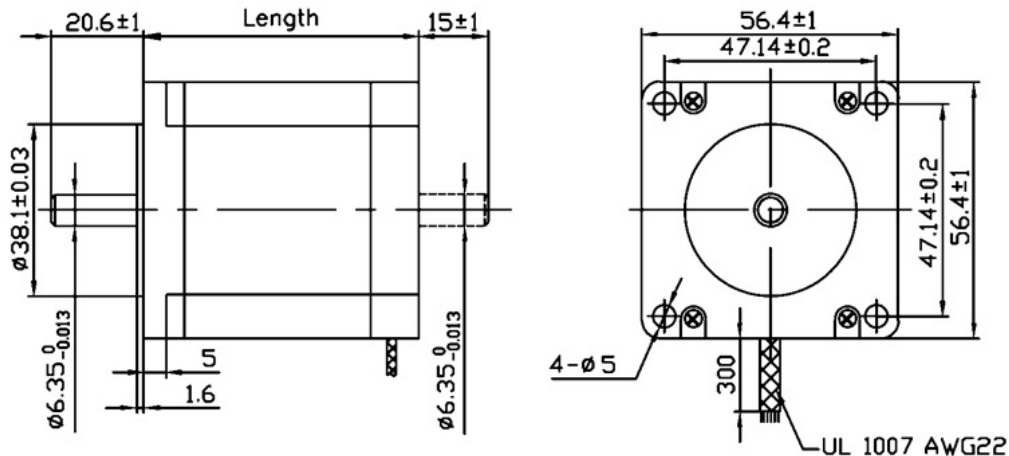

Connection

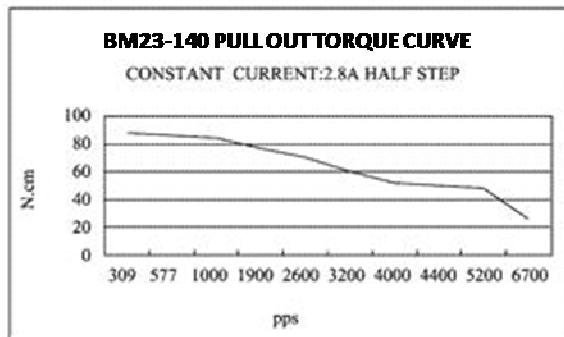
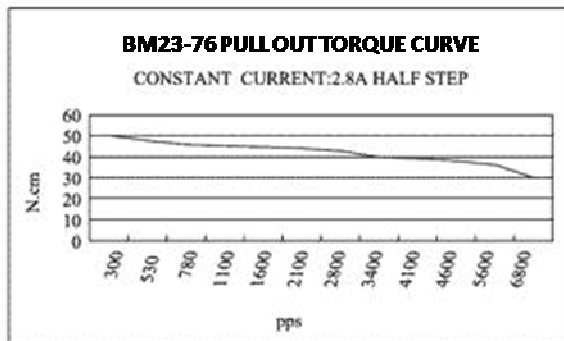
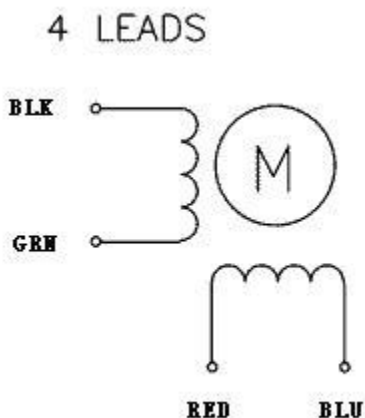

Torque Speed Curves

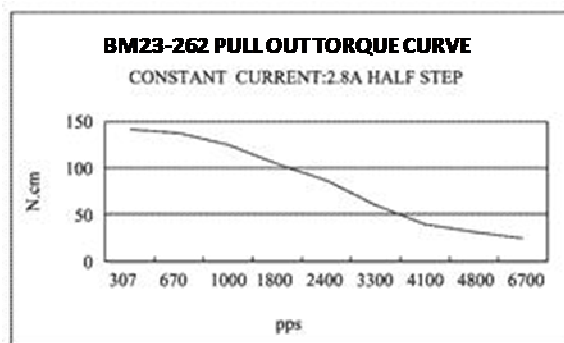
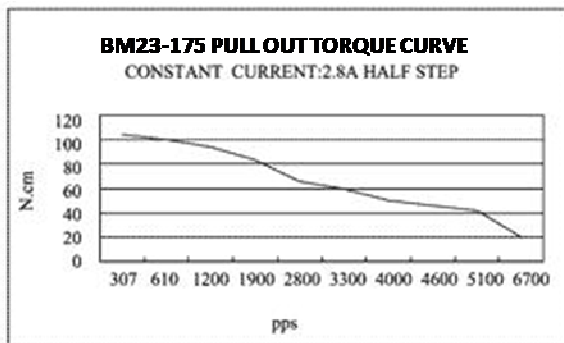

Encoder (Option)

500 LINE ENCODER OPTION

DIMENSIONS- inches (mm)

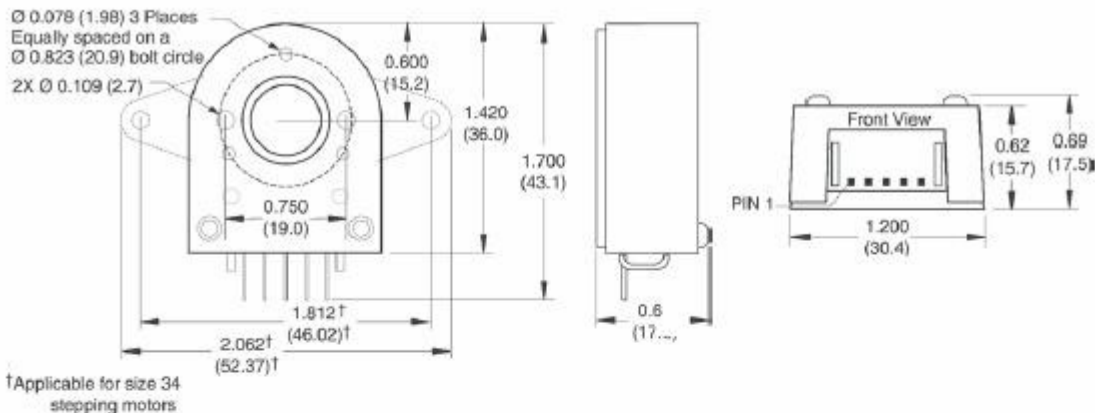

ENCODER PIN ASSIGNMENTS

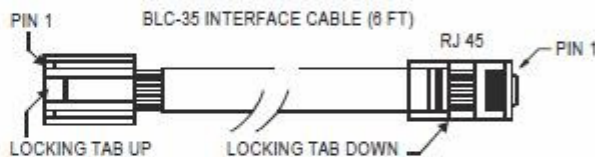
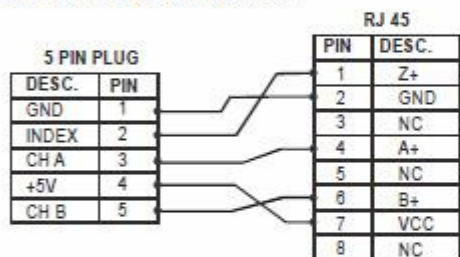

Note: All AM Series motors with the encoder option come standard with the BLC-35 interface cable.

ENCODER TIMING DIAGRAM

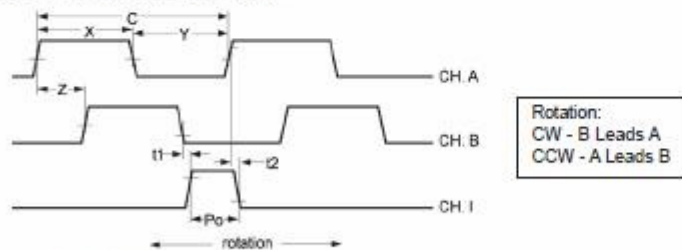

Characteristics

Parameter	Symbol	Min	Typ	Max	Units
Cycle Error			3	5.5	°e
Symmetry		130	180	230	°e
Quadrature		40	90	140	°e
Index Pulse Width	Po	60	90	120	°e
Index Rise After CH B or CH A fall	t1	-300	100	250	ns
Index Fall After CH A or CH B rise	t2	70	150	1000	ns